



AC output side



DC input side



Features

- Combining AC/DC charger, DC/AC Inverter, AC by-pass & support external MPPT solar charger
- AC utility charger up to 4520W
- UPS function (AC by-pass) without interruption, transfer time <10ms
- True sine wave output (THD<3%)
- High surge power up to 10KW
- Parallel synchroized operation up to 30KW (5+1 unit)
- Temperature controlled cooling fan
- AC output voltage and frequency selectable by DIP S.W
- Protections :
Input : Reverse polarity / DC low alarm / DC low shutdown / Over voltage
Output : Short circuit / Overload / Over temp.
- Battery over discharge protection (low voltage disconnect)
- -30°C~+70°C wide operating temperature
- Suitable for lead-acid or li-ion batteries
- Support MODBus-RTU(RS-485) communication
- Conformal coating
- 5 years warranty

Applications

- Home and office appliance
- Power tools
- Portable equipment
- Vehicle
- Yacht
- Off-grid solar power system
- Wireless network
- Telecom or datacom system

Description

NTN-5K is a 5000W highly reliable off-grid true sine wave DC-AC power inverter with built-in AC charger and UPS function(AC by-pass). Its key features include: digital design with MCU control, streamlined control circuitry that quickly responds to environmental changes and improves reliability, high quality fan with low acoustic noise, 10KW peak power, adjustable AC output voltage and frequency, -30~+70°C wide operating temperature range, complete protection features, and etc. Combined with batteries, the NTN-5K is suitable for use in residential, commercial, marine, automobile, mine, construction site, and remote areas with no access to utility power, and the output can be used to power fans, TV, radio, phone charger, PC/laptop, lighting, induction stove, air conditioner, electromechanical tool, communication equipment, power distribution cabinet, outdoor camping equipment, marine AC power, factory equipment, and etc.

Model Encoding

NTN - 5K - 2 24

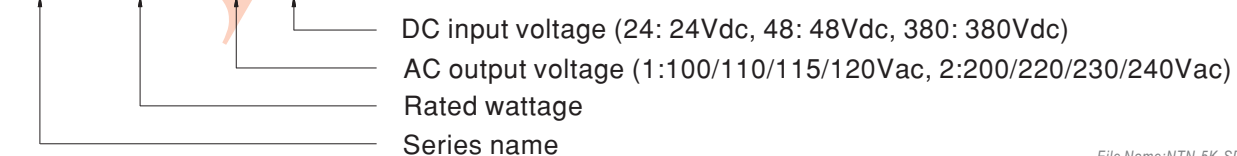

SPECIFICATION

MODEL NO.		NTN-5K-224	NTN-5K-248	NTN-5K-2380		
AC OUTPUT	RATED POWER(Continuous)	5000W				
	OVER RATED POWER(3 Min.)	5750W				
	PEAK POWER(10 Sec.)	7000W	7500W			
	SURGE POWER(30 Cycles)	8000W	10000W			
	AC VOLTAGE	Default setting set at 230VAC 200 / 220 / 230 / 240Vac selectable by DIP S.W				
	FREQUENCY	Default setting set at 50 ± 0.1Hz 50/60Hz selectable by DIP S.W				
	WAVEFORM	Note.1 True sine wave (THD<3%)				
AC REGULATION		± 3.0% at rated input voltage				
DC INPUT	DC VOLTAGE	24Vdc	48Vdc	380Vdc		
	VOLTAGE RANGE (Typ.)	20 ~ 33Vdc	40 ~ 66Vdc	280 ~ 430Vdc		
	DC CURRENT (Typ.)	240A	120A	16A		
	NO LOAD DISSIPATION (Typ.)	NON-SAVING MODE	2.5A	1.4A	0.2A	
		SAVING MODE	Default disable, auto detect AC output load ≤ 10W will be changed to saving mode <25W			
	OFF MODE CURRENT DRAW	≤ 1mA				
	EFFICIENCY (Typ.)	Note.1	91%	93%	94.5%	
BATTERY TYPES		Lead Acid or li-ion				
PROTECTION	DC INPUT	LOW	ALARM	22 ± 0.5Vdc	44 ± 1Vdc	300 ± 5Vdc
			SHUTDOWN	20 ± 0.5Vdc	40 ± 1Vdc	280 ± 5Vdc
			RESTART	25 ± 0.5Vdc	50 ± 1Vdc	335 ± 5Vdc
		HIGH	ALARM	31 ± 0.5Vdc	62 ± 1Vdc	420 ± 5Vdc
			SHUTDOWN	33 ± 0.5Vdc	66 ± 1Vdc	430 ± 5Vdc
			RESTART	30 ± 0.5Vdc	60 ± 1Vdc	400 ± 5Vdc
	BAT. POLARITY		No indication. after power on			
	AC OUTPUT	OVER TEMPERATURE	Shut down o/p voltage, recovers automatically after temperature goes down			
		OUTPUT SHORT	Shut down o/p voltage, re-power on to recover			
		OVER LOAD (Typ.)	105 ~ 115% load for 180 sec., 115% ~ 140% load for 10 sec. 105 ~ 115% load for 180 sec., 115% ~ 150% load for 10 sec. Protection type : Shut down o/p voltage, re-power on to recover			
CIRCUIT BREAKER		35A				
FUNCTION	REMOTE CONTROL	Power ON-OFF remote control by front panel dry contact connector(by RELAY), Open : Remote off ; Short : Normal work				
	COMMUNICATION	MODBus-RTU (RS-485)				
AC UPS MODE	AC INPUT RANGE	200/220/230/240Vac ± 16%, recover ± 13%				
	FREQUENCY RANGE	45 ~ 65Hz				
	TRASFER TIME(Typ.)	10ms inverter → AC by pass				
AC CHARGER	BOOST CHARGE VOLTAGE	Default 28.8Vdc	Default 57.6Vdc	Default 400Vdc		
	FLOAT CHARGE VOLTAGE	Default 27.6Vdc	Default 55.2Vdc	Default 385Vdc		
	CHARGE VOLTAGE RANGE	21 ~ 30Vdc	42 ~ 60Vdc	300 ~ 400Vdc		
	CONSTANT CURRENT	135A	70A	11.3A		
	MAX. CHARGE POWER	4050W	4200W	4520W		
	TEMPERATURE COMPENSATION	By external NTC				
ENVIRONMENT	WORKING TEMP.	-30 ~ +70°C (Refer to "Derating curve")				
	WORKING HUMIDITY	20% ~ 90% RH non-condensing				
	STORAGE TEMP., HUMIDITY	-30 ~ +70°C / -22 ~ +158°F, 10 ~ 95% RH non-condensing				
	VIBRATION	10 ~ 500Hz, 3G 10min./1cycle, 60min. each along X, Y, Z axes				
SAFETY & EMC (Note.4)	SAFETY STANDARDS	CB IEC62368-1, CSA C22.2 No. 62368-1, TUV BS EN/EN62368-1, AS/NZS 62368.1, EAC TP TC 004 approved				
	WITHSTAND VOLTAGE	DC I/P - AC:3.0KVAC AC - FG:1.5KVAC				
	ISOLATION RESISTANCE	DC I/P - AC O/P, DC I/P - FG, AC O/P - FG: 100M ohms / 500VDC / 25°C / 70% RH				
	EMC EMISSION	Parameter	Standard	Test Level / Note		
		Radiated	BS EN/EN55032(CISPR32)	Class A		
		Conducted	BS EN/EN55032(CISPR32)	Class A		
		Harmonic Current	BS EN/EN61000-3-2	Class A		
	Voltage Flicker	BS EN/EN61000-3-3	-----			
	EMC IMMUNITY	BS EN/EN55024, BS EN/EN55035				
		Parameter	Standard	Test Level / Note		
ESD		BS EN/EN61000-4-2	Level 3, 8KV air ; Level 2, 4KV contact			
Radiated		BS EN/EN61000-4-3	Level 2			
EFT / Burst		BS EN/EN61000-4-4	Level 2, 1KV			
Surge		BS EN/EN61000-4-5	Level 3, 1KV/Line-Line 2KV/Line-Earth			
Conducted		BS EN/EN61000-4-6	Level 2			
Magnetic Field		BS EN/EN61000-4-8	Level 1			
Voltage Dips and Interruptions	BS EN/EN61000-4-11	>95% dip 0.5 periods, 30% dip 25 periods, >95% interruptions 250 periods				
OTHERS	MTBF	200.9K hrs min. Telcordia TR/SR-332 (Bellcore) ; 17.8K hrs min. MIL-HDBK-217F (25°C)				
	DIMENSION	460*211*83.5mm (L*W*H)				
	PACKING	10.5Kg; 1pcs/ 10.5Kg/ 1.25CUFT				
NOTE	<p>1.Efficiency, AC regulation and THD are tested by 75% load, linear load at 25Vdc/50Vdc/400Vdc input voltage.</p> <p>2.All parameters not specified above are measured at 25Vdc/50Vdc/400Vdc input and 25°C of ambient temperature and set to factory setting.</p> <p>3.The tolerance of each voltage value by models is: 224 → ± 1V; 248 → ± 2V; 2380 → ± 5V.</p> <p>4.The power supply is considered as an independent unit, but the final equipment still need to re-confirm that the whole system complies with the EMC directives. For guidance on how to perform these EMC tests, please refer to "EMI testing of component power supplies." (as available on https://www.meanwell.com/Upload/PDF/EMI_statement_en.pdf)</p> <p>※ Product Liability Disclaimer : For detailed information, please refer to https://www.meanwell.com/serviceDisclaimer.aspx</p>					

SPECIFICATION

MODEL NO.		NTN-5K-124	NTN-5K-148		
AC OUTPUT	RATED POWER(Continuous)	4000W			
	OVER RATED POWER(3 Min.)	4600W			
	PEAK POWER(10 Sec.)	6000W			
	SURGE POWER(30 Cycles)	8000W			
	AC VOLTAGE	Default setting set at 110VAC 100 / 110 / 115 / 120Vac selectable by DIP S.W			
	FREQUENCY	Default setting set at 60 ±0.1Hz 50/60Hz selectable by DIP S.W			
	WAVEFORM	Note.1 True sine wave (THD<3%)			
AC REGULATION		±3.0% at rated input voltage			
DC INPUT	DC VOLTAGE	24Vdc	48Vdc		
	VOLTAGE RANGE (Typ.)	20 ~ 33Vdc	40 ~ 66Vdc		
	DC CURRENT (Typ.)	200A	100A		
	NO LOAD DISSIPATION (Typ.)	NON-SAVING MODE	2.5A	1.4A	
		SAVING MODE	Default disable, auto detect AC output load ≤ 10W will be changed to saving mode <25W		
	OFF MODE CURRENT DRAW	≤ 1mA			
	EFFICIENCY (Typ.)	Note.1	89%	91%	
BATTERY TYPES		Lead Acid or li-ion			
PROTECTION	DC INPUT	LOW	ALARM	22 ±0.5Vdc	44 ±1Vdc
			SHUTDOWN	20 ±0.5Vdc	40 ±1Vdc
			RESTART	25 ±0.5Vdc	50 ±1Vdc
		HIGH	ALARM	31 ±0.5Vdc	62 ±1Vdc
			SHUTDOWN	33 ±0.5Vdc	66 ±1Vdc
			RESTART	30 ±0.5Vdc	60 ±1Vdc
	BAT. POLARITY		No indication. after power on		
	AC OUTPUT	OVER TEMPERATURE	Shut down o/p voltage, recovers automatically after temperature goes down		
		OUTPUT SHORT	Shut down o/p voltage, re-power on to recover		
		OVER LOAD (Typ.)	105 ~ 115% load for 180 sec., 115% ~ 150% load for 10 sec. Protection type : Shut down o/p voltage, re-power on to recover		
CIRCUIT BREAKER		50A			
FUNCTION	REMOTE CONTROL	Power ON-OFF remote control by front panel dry contact connector(by RELAY), Open : Remote off ; Short : Normal work			
	COMMUNICATION	MODBus-RTU (RS-485)			
AC UPS MODE	AC INPUT RANGE	100/110/115/120Vac ± 16%, recover ± 13%			
	FREQUENCY RANGE	45 ~ 65Hz			
	TRANSFER TIME(Typ.)	10ms inverter → AC by pass			
AC CHARGER	BOOST CHARGE VOLTAGE	Default 28.8Vdc	Default 57.6Vdc		
	FLOAT CHARGE VOLTAGE	Default 27.6Vdc	Default 55.2Vdc		
	CHARGE VOLTAGE RANGE	21 ~ 30Vdc	42 ~ 60Vdc		
	CONSTANT CURRENT	120A	60A		
	MAX. CHARGE POWER	4050W	4200W		
	TEMPERATURE COMPENSATION	By external NTC			
ENVIRONMENT	WORKING TEMP.	-30 ~ +70 °C (Refer to "Derating curve")			
	WORKING HUMIDITY	20% ~ 90% RH non-condensing			
	STORAGE TEMP., HUMIDITY	-30 ~ +70 °C / -22 ~ +158 °F, 10 ~ 95% RH non-condensing			
	VIBRATION	10 ~ 500Hz, 3G 10min./1cycle, 60min. each along X, Y, Z axes			
SAFETY & EMC (Note.4)	SAFETY STANDARDS		CB IEC62368-1, TUV BS EN/EN62368-1 approved		
	WITHSTAND VOLTAGE		DC I/P - AC I/P:3.0KVAC DC I/P - AC O/P:3.0KVAC AC O/P - FG:1.5KVAC		
	ISOLATION RESISTANCE		DC I/P - AC O/P, DC I/P - FG, AC O/P - FG: 100M ohms / 500VDC / 25 °C / 70% RH		
	EMC EMISSION	Parameter	Standard	Test Level / Note	
		Radiated	FCC	Class A	
		Conducted	FCC	Class A	
		Harmonic Current	BS EN/EN61000-3-2	Class A	
	Voltage Flicker	BS EN/EN61000-3-3	-----		
	EMC IMMUNITY	BS EN/EN55024, BS EN/EN55035			
		Parameter	Standard	Test Level / Note	
ESD		BS EN/EN61000-4-2	Level 3, 8KV air ; Level 2, 4KV contact		
Radiated		BS EN/EN61000-4-3	Level 2		
EFT / Burst		BS EN/EN61000-4-4	Level 2, 1KV		
Surge		BS EN/EN61000-4-5	Level 3, 1KV/Line-Line 2KV/Line-Earth		
Conducted		BS EN/EN61000-4-6	Level 2		
Magnetic Field		BS EN/EN61000-4-8	Level 1		
Voltage Dips and Interruptions	BS EN/EN61000-4-11	>95% dip 0.5 periods, 30% dip 25 periods, >95% interruptions 250 periods			
OTHERS	MTBF	200.9K hrs min. Telcordia TR/SR-332 (Bellcore) ; 17.8K hrs min. MIL-HDBK-217F (25 °C)			
	DIMENSION	460*211*83.5mm (L*W*H)			
	PACKING	10.5Kg; 1pcs/ 10.5Kg/ 1.25CUFT			
NOTE	<p>1.Efficiency, AC regulation and THD are tested by 75% load, linear load at 25Vdc/50Vdc input voltage.</p> <p>2.All parameters not specified above are measured at 25Vdc/50Vdc/400Vdc input and 25 °C of ambient temperature and set to factory setting.</p> <p>3.The tolerance of each voltage value by models is: 124 → ± 1V; 148 → ± 2V.</p> <p>4.The power supply is considered as an independent unit, but the final equipment still need to re-confirm that the whole system complies with the EMC directives. For guidance on how to perform these EMC tests, please refer to "EMI testing of component power supplies." (as available on https://www.meanwell.com/Upload/PDF/EMI_statement_en.pdf)</p> <p>※ Product Liability Disclaimer : For detailed information, please refer to https://www.meanwell.com/serviceDisclaimer.aspx</p>				

DERATING CURVE

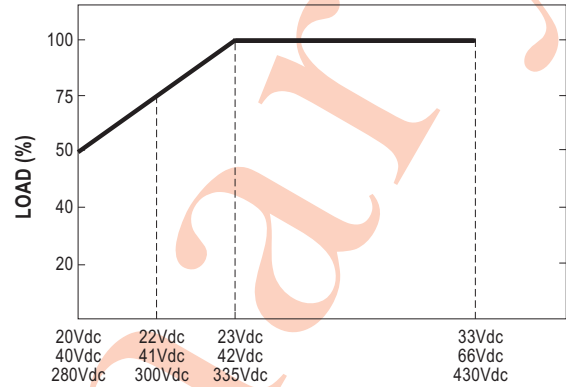
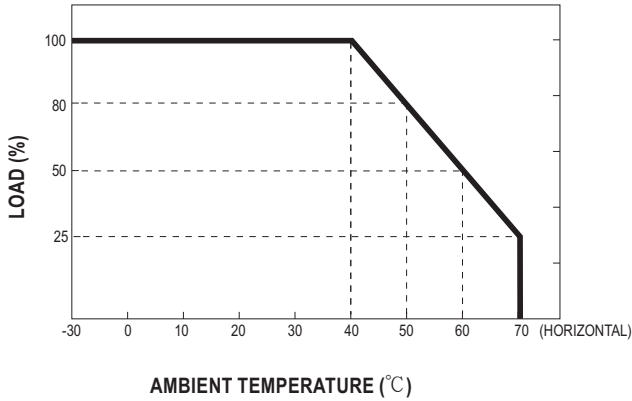

CHARGING CURVE

☉ Default 3 stage charging curve

3 Stage

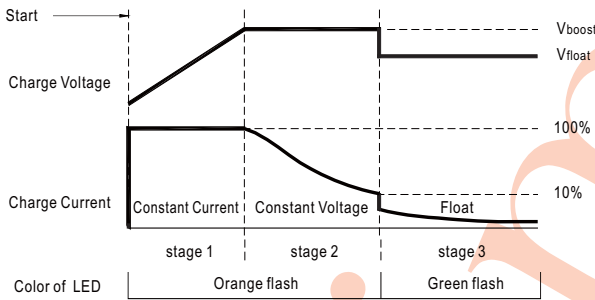

☉ Embedded 3 stage charging curves

MODEL	Vboost	Vfloat	C.C	Adjustable by MODBus
24Vdc	Default 28.8Vdc	27.6Vdc	135A max.	21~30Vdc
48Vdc	Default 57.6Vdc	55.2Vdc	70A max.	42~60Vdc
380Vdc	Default 400Vdc	385Vdc	11.3A max.	300~400Vdc

☉ Suitable for lead-acid batteries (flooded, Gel and AGM) or li-ion

BLOCK DIAGRAM

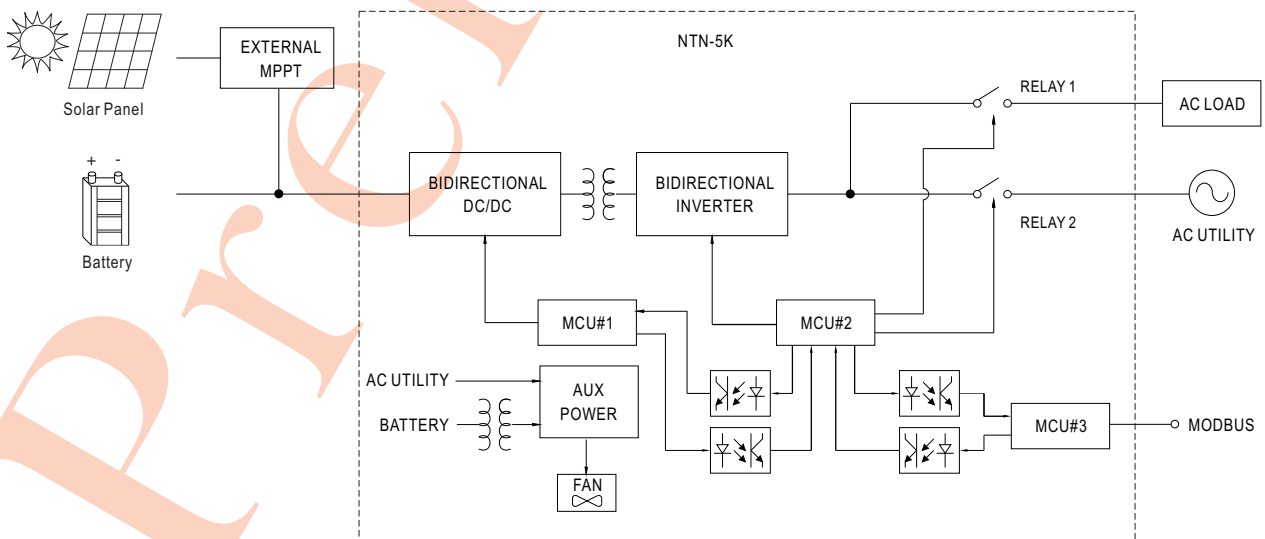

■ Function Manual

1.Support RS-485 Communication

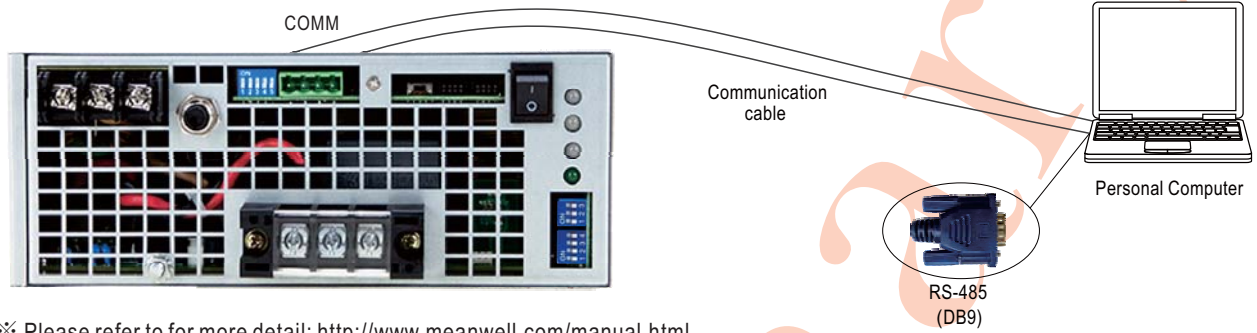

※ Please refer to for more detail: <http://www.meanwell.com/manual.html>

2.Remote ON-OFF Control

PAR1/PAR2	Remote ON-OFF	AC Output Status
Pin1:3	Short	Power inverter ON
Pin1:3	Open	Power inverter OFF

3.AC Output Voltage, Frequency, Power saving mode selectable by DIP SW



AC Output Voltage, Frequency, Power saving mode selectable by DIP SW			
S1	S2	S3	S4
OFF	OFF : 100Vac or 200Vac	ON : 50Hz	ON : Saving mode
OFF	ON : 110Vac or 220Vac		
ON	OFF : 115Vac or 230Vac	OFF: 60Hz	OFF: Non-Saving mode
ON	ON : 120Vac or 240Vac		

4. 3Ø 4W AC output Voltage connection selectable by DIP SW



©3Ø 4-wire / Y

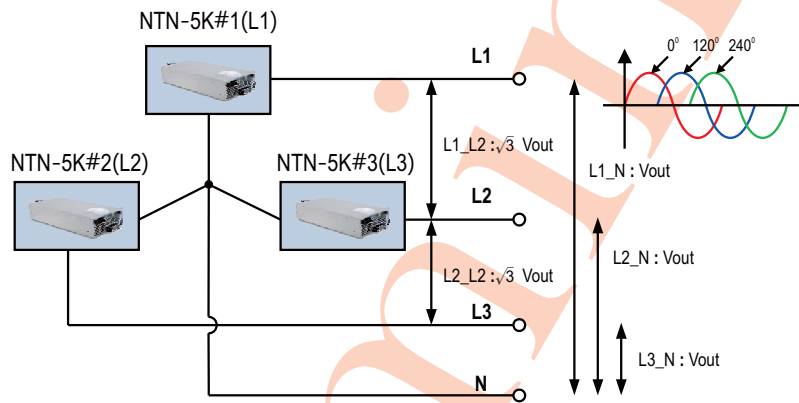

Fig 1.1

S1	S2	AC output phase
OFF	OFF	L1, 0°
OFF	ON	L2, +120°
ON	OFF	L3, +240°

5. Temperature compensation (3 stage only)

Temperature compensation function to prolong battery life for lead-acid batteries. Temperature compensation range is 0 ~ 40°C.

The battery temperature sensor comes along with the charger can be connected to the unit to allow temperature compensation of the charging voltage.

If the sensor is not used, the charger works normally.



6.AC Output Parallel Function

NTN-5K has the built-in active current sharing function and can be connected in parallel, up to 6 units, to provide higher AC output power as exhibited below :

- ※ The inverter should be paralleled using short and large diameter wiring and then connected to the load.
- ※ The total output current must not exceed the value determined by the following equation:

Maximum output current at parallel operation = (Rated current per unit) x (Number of unit) x 95% ; when parallel unit less than 6.

- ※ PAR1/PAR2, PRL Function pin connection

Parallel	PSU1		PSU2		PSU3		PSU4		PSU5		PSU6	
	PAR1	PRL	PAR1	PRL	PAR1	PRL	PAR1	PRL	PAR1	PRL	PAR1	PRL
1 unit	X	ON	—	—	—	—	—	—	—	—	—	—
2 unit	V	ON	V	ON	—	—	—	—	—	—	—	—
3 unit	V	ON	V	OFF	V	ON	—	—	—	—	—	—
4 unit	V	ON	V	OFF	V	OFF	V	ON	—	—	—	—
5 unit	V	ON	V	OFF	V	OFF	V	OFF	V	ON	—	—
6 unit	V	ON	V	OFF	V	OFF	V	OFF	V	OFF	V	ON

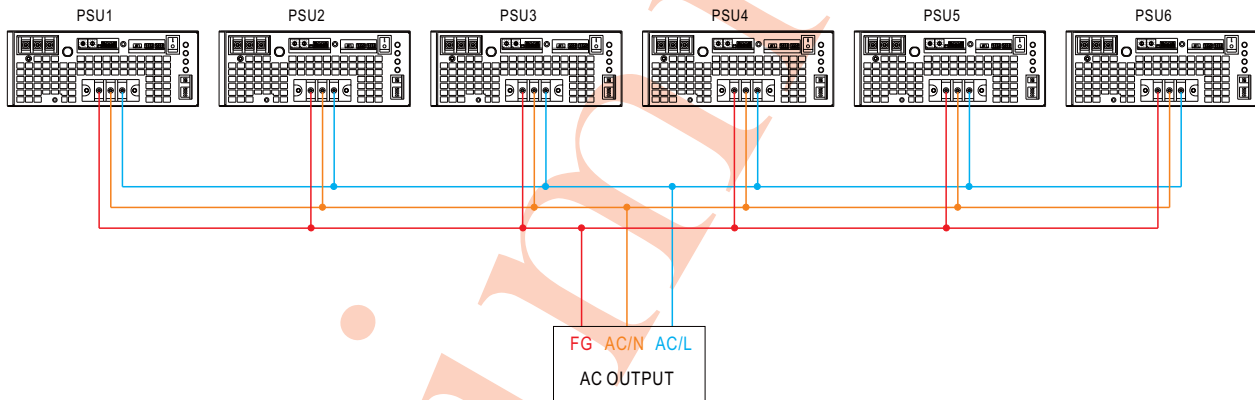
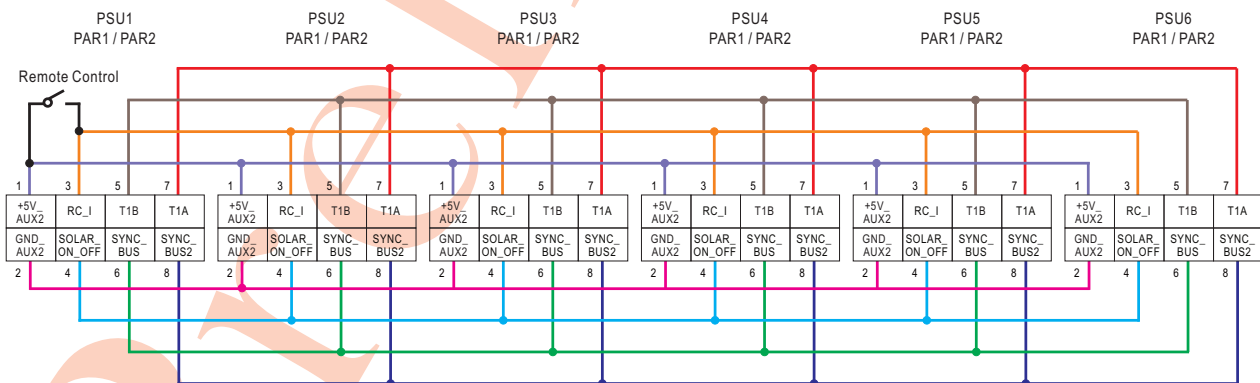

Fig 6.1



If the lines of PAR1 / PAR2 are too long, they should be twisted in pairs to avoid the noise.

■ LED STATUS

Normal work:

	Green	Orange	Red
Status	Inverter OK	Remote off	Abnormal Status (See below table)
	System check	Saving mode	

	Green	Orange	Red
DC Input	25~31Vdc	22~25Vdc	<22Vdc or >31Vdc <44Vdc or >62Vdc <260Vdc or >370Vdc
	50~62Vdc	44~50Vdc	
	300~370Vdc	260~300Vdc	
	Maintain	Charging	

	Green	Orange	Red
Load	<40% load	40~80% load	>80% load

	Green	Orange	Red
AC Input	Utility OK	-----	-----
	Utility error	-----	-----
	Utility disconnected		





Abnormal status :

LED Indicator	Abnormal Indication
Status DC Input Load	Output overload or AC output short circuit
Status DC Input Load	Abnormal DC voltage
Status DC Input Load	Over temperature or Fan lock
Status DC Input Load	Inverter fail

- Light
- Light off
- Flash

■ Accessory List

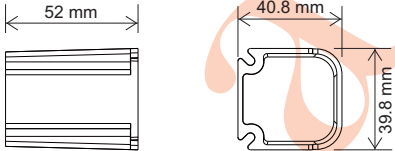
※ Terminal protector mating along with NTN-5K (Standard accessory)

①			Quantity
②			1
③			4

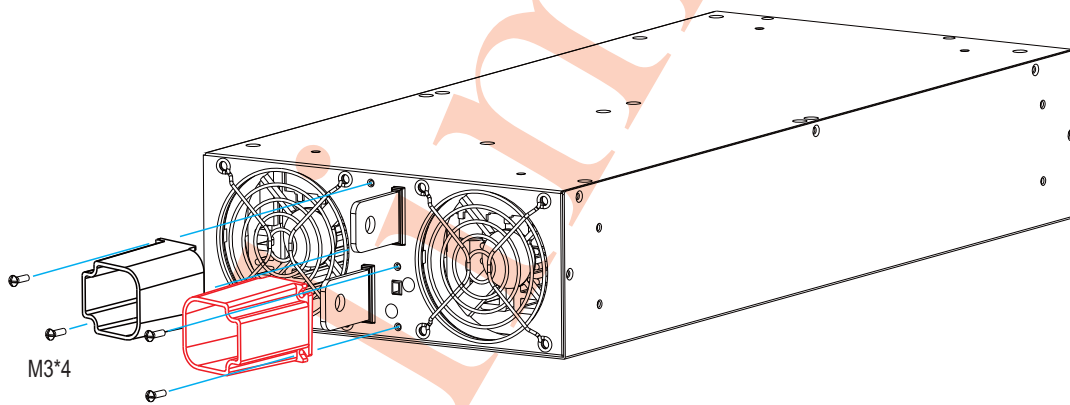

■ TYPICAL APPLICATION



- 1 Battery Bank
- 2 Off-Grid DC/AC Inverter (NTN series)
- 3 AC Outlet

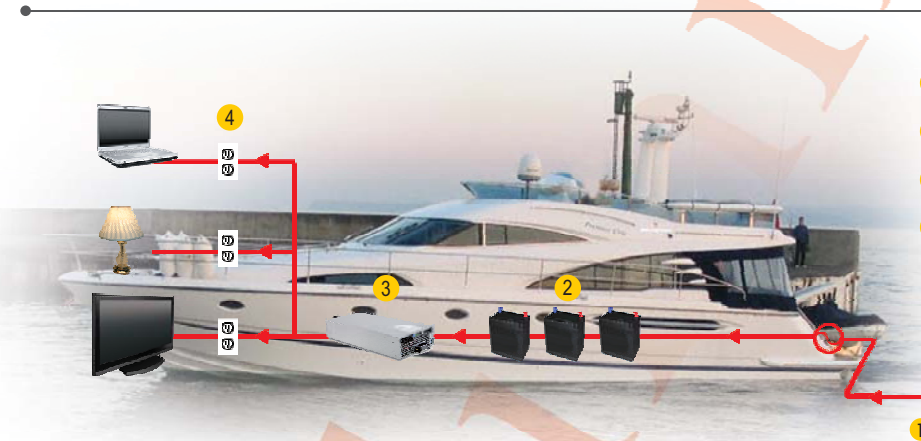

- 1 Utility Input (Shore)
- 2 Battery Bank
- 3 Off-Grid DC/AC Inverter (NTN series)
- 4 AC Outlet

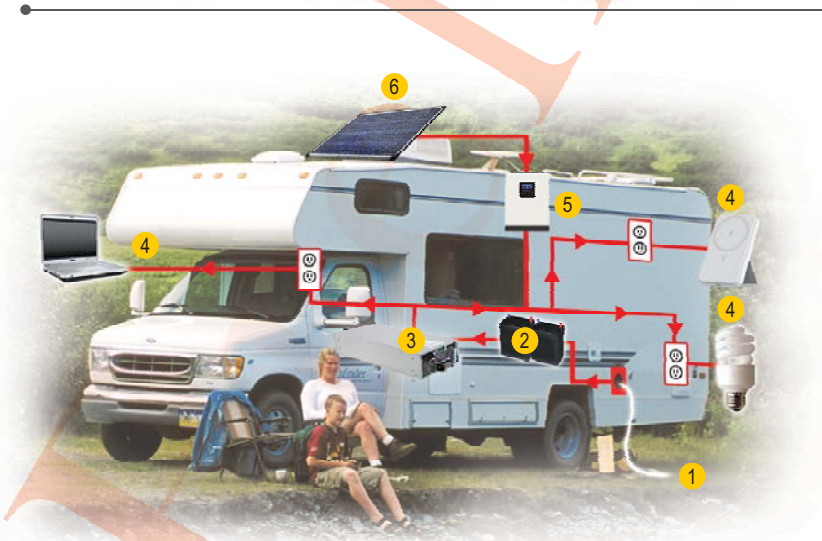

- 1 Utility Inlet
- 2 Battery Bank
- 3 Off-Grid DC/AC Inverter (NTN series)
- 4 AC Outlet
- 5 MPPT Charger (External)
- 6 Solar Panel (External)

■ SYSTEM CONFIGURATION

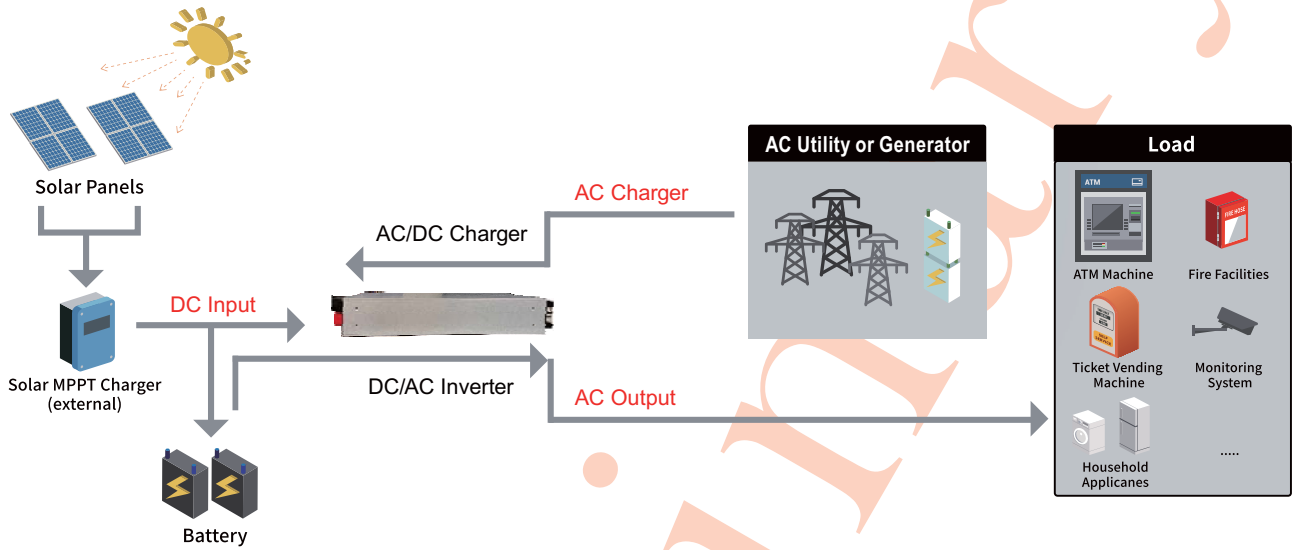

- 1 Battery Bank
- 2 Off-Grid DC/AC Solar Inverter (NTN series)
- 3 AC Outlet